

# ESKA

[www.eskavalve.com](http://www.eskavalve.com)



**ERG**  
**SERIES**

**INTRODUCTORY**

ERG series gas pressure regulators are used in the gas lines in order to reduce maximum 1 bar input pressure to the desired output pressure between 16 and 150 mbar. The range of the output pressure can be set with the choice of a different spring.



**ERG 1015 - 1020 - 1025**



**ERG 1032 - 1040 - 1050**

## TECHNICAL INFORMATION

- Usage : City gas networks and gas pipelines in industrial areas
- Medium : Non-corrosive gases such as Natural Gas (Methane), LPG, Town Gas, Air, etc...
- Pressure Class : PN1
- Connection or Port Size : 1/2", 3/4", 1", 1 1/4", 1 1/2", 2" Threaded (Female)
- Inlet Pressure Range : 50 mbar up to 1 bar
- Outlet Pressure Range : 16 mbar up to 150 mbar
- Filter : Optional
- Number of Stages : Single Stage
- Accuracy Class : AC 10 ( $\pm 10\%$ ) (On Request AC5, AC15, AC20)
- Lock Up Pressure Class : SG30 (+ 30%) (On Request SG10, SG20))
- Ambient Temperature : -20°C up to 60°C (On request -40 °C)
- Material Standard : Aluminum-EN 1706 / Brass-EN 12164 and EN 12165 / Rubber-EN 549
- According to Directives : 2014/68/EU

## ERG SERIES CAPACITY GRAPH

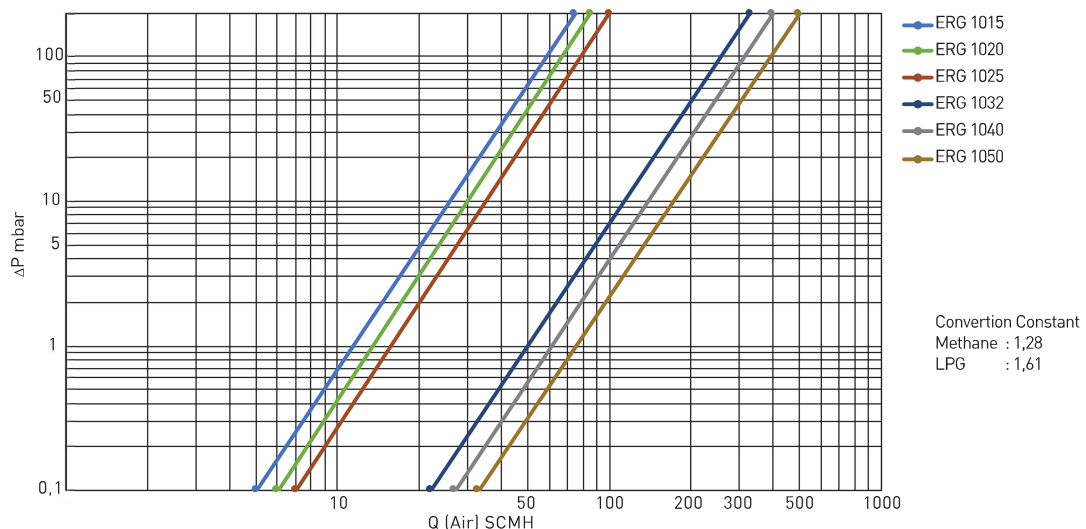

**CONFIGURATIONS**

INLINE

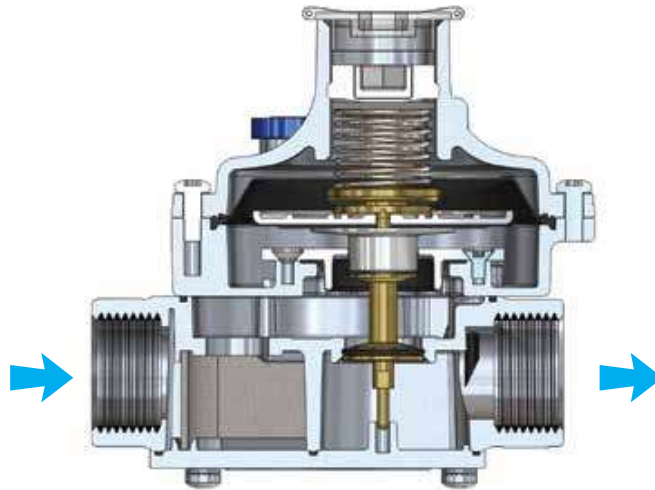

ERG 1015 - 1020 - 1025

INLINE

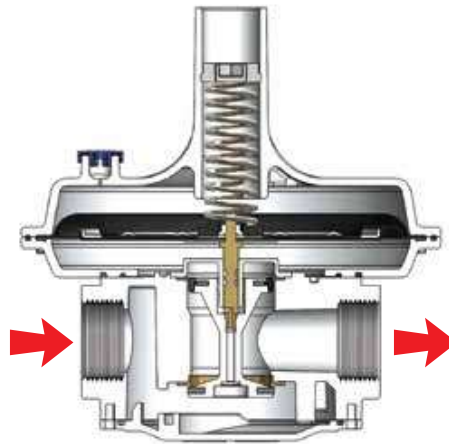

ERG 1032 - 1040 - 1050

CONNECTION	OUTLET PRESSURE (21mbar)
1/2"	20 m <sup>3</sup> /h
3/4"	25 m <sup>3</sup> /h
1"	35 m <sup>3</sup> /h
1 1/4"	85 m <sup>3</sup> /h
1 1/2"	100 m <sup>3</sup> /h
2"	120 m <sup>3</sup> /h

FLOW RATE TABLE (FOR NATURAL GAS) AT INLET PRESSURE 300 mbar ACCURACY CLASS AC10

**DIMENSIONS**

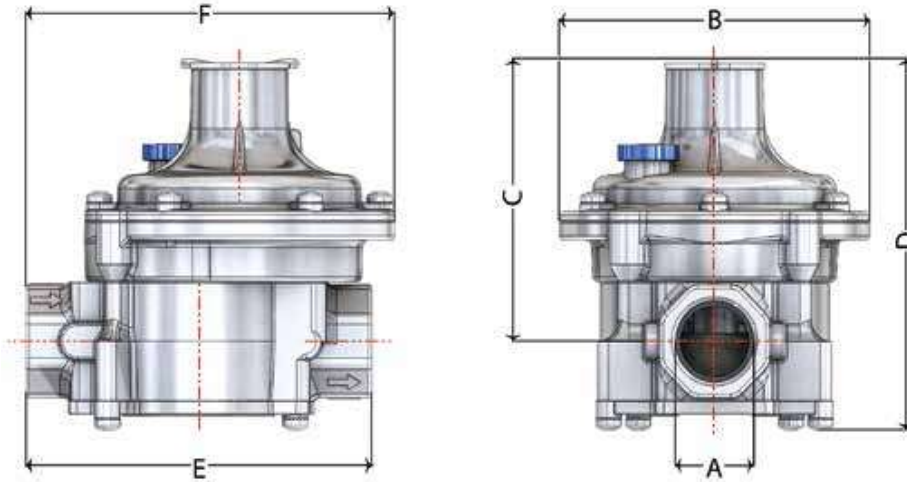

MODEL	A	B	C	D	E	F
ERG 1015	1/2"	122	107	141	136	145
ERG 1020	3/4"	122	107	141	136	145
ERG 1025	1"	122	107	141	136	145

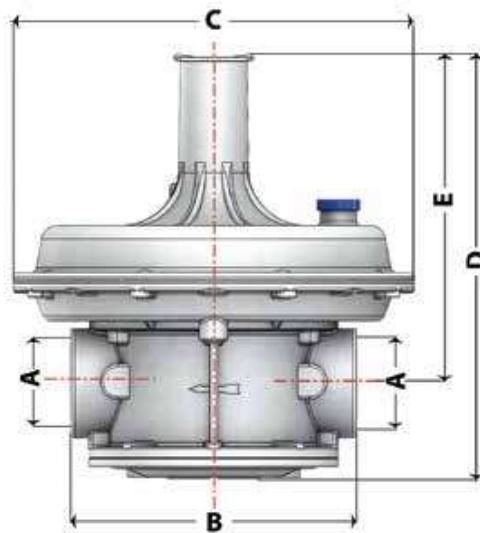

MODEL	A	B	C	D	E
ERG 1032	1 1/4"	160	225	237	183
ERG 1040	1 1/2"	160	225	237	183
ERG 1050	2"	162	225	259	192