



MacBAT 5

Gas volume and energy electronic conversion device with intergrated GSM 2G/3G/LTE modem

MacBAT 5 is a gas volume corrector that enables PTZ, PT or T conversion. The device is designed to measure volume, energy and flow of gas. Primarily battery powered with the possibility to connect external power supply. The device converts the volume of gas counted by the gas meter (turbine, rotary, ultrasonic) into the base conditions. Gas compressibility factor is calculated with the use of algorithms SGERG-88, MGERG-88, AGA8-92DC, AGA8-G1, AGA8-G2, AGA NX-19 mod or constant value of relative compression factor. MacBAT 5 is an intrinsically safe device ready to be installed in explosive hazardous zone 0.

Main features of the MacBAT 5

- Industrial housing cooperates with various types of gas meter like turbine, rotary, ultrasonic directly by LF, HF, Namur, Encoder, Wiegand
- 4 independent serial transmission ports (2xRS485 + OPTICAL INTERFACE 62056-21+ NFC IEC 14443)
- Built-in GSM/GPRS modem (option)
- Backlight graphic display
- 5 configurable binary Ex inputs
- 2 configurable binary NAMUR Ex inputs (operating on battery mode)
- Binary and frequency outputs
- Internal or external pressure transducers available
- More than 10 years of archive registered data storage (with monthly sampling interval)



Technical specification

Dimensions	206x194x76 mm								
Weight	1,3 kg								
Housing material	Polycarbonate enclosure (version 1) or metal (version 2)								
Relative humidity	max 95% at temp. 70°C								
Ambient temperature range	-25°C up to 70°C								
Housing protection class	IP 66 (for outdoor installation)								
Keyboard	6 pushbuttons (version 1) or 18 pushbuttons (version 2)								
Display	LCD - graphic 4" with backlight								
Ex classification	 II 1 G Ex ia IIB T4 Ga Certificate FTZU 17 ATEX 0047X								
Internal EVC supply	D-size lithium battery 3,6V/17Ah (up to 3 batteries in version without modem), operating time: One battery: 5 years								
Internal GSM supply	Two D-size lithium batteries 3,6V/17Ah, operating time: 5 years (two communications per day)								
External supply	<ul style="list-style-type: none"> Intrinsically safe power supply and transmission interface INT-S3 (RS485, Supply output 5.7V, 2 digital inputs/ outputs, Supply input 11÷30V DC) 								
Transmission ports	<ul style="list-style-type: none"> 2 independent serial transmission ports, speed up to 256 000 b/s: COM1, COM2 standard RS-485 Optical Interface IEC 62056-21 NFC interface IEC 14443 GSM/GPRS 2G/3G/LTE (option) 								
Transmission protocols	MODBUS RTU, MODBUS TCP (in version with internal modem), MODBUS RTU (MASTER MODE), GAZMODEM, GAZMODEM (MASTER MODE). Other protocols can be used on request.								
Environment conditions class (Mechanical/Electromagnetic)	M2/E2								
Base conditions	Adjustable by authorized service personnel, available options: <ul style="list-style-type: none"> Base pressure (absolute) pb: range (1,00÷1,02) bar, default 1,01325 bar Base temperature Tb: range (270÷300) K, default 273,15K (0°C) Reference temperature for combustion process T1: range (270÷300) K, default 298,15K (25°C) 								
The maximum permissible error (MPE) according to standard „EN 12405-1”	0,5 % at reference conditions 1 % at nominal operating conditions typical error < 0,15%								
The maximum permissible error (MPE) according to standard „EN 12405-2”	ECD Class A								
Used algorithms for calculations of compression factor	SGERG-88, MGERG-88, AGA8-92 Detailed Composition, AGA8-G1, AGA8-G2, AGA NX-19 mod constant compression factor K1								
Registration periods	<ul style="list-style-type: none"> Data registered periodically: logging interval from 1 up to 60 minutes – 24000 records Hourly data: more than 2 years Daily data: more than 3 years Monthly data: more than 10 years Events memory: approximately 4000 records (segmented for 2 sectors) 								
Meets the requirements specified in Standard 2004/22/WE (MID)									
Inputs	<ul style="list-style-type: none"> 6 Ex digital inputs - to cooperate with Potential-free junctions, shared with: <ul style="list-style-type: none"> 2 LF inputs, frequency 0÷60Hz, reed contact, WIEGAND 1 TS tamper protection switch (closed by default) 2 Ex digital inputs, NAMUR type, shared with: <ul style="list-style-type: none"> 2 HF inputs, frequency 0÷5000Hz EN60947-5-6, a possibility of temporary work on battery 1 ENCODER (NAMUR type) 1 SCR ENCODER Pressure sensor p1 (internal or external) - measurement range in standard option - up to 6 bar. End of the sensor is a metric screw thread M12 x 1.5 (Ermeto), pressure ranges: 0.8÷6 / 0.8÷10 / 2÷10 / 4÷20 / 7÷35 / 4÷70 / 10÷70 / 10÷100 / bar abs. Maximum permissible errors for measurements of p <table border="0" style="margin-left: 20px;"> <tr> <td>20 °C (± 3 °C)</td> <td>(-25÷55) °C</td> </tr> <tr> <td>± 0,2 % of measured value</td> <td>± 0,35 % of measured value</td> </tr> </table> Temperature sensor Pt1000 class A or B, 2-wire or 4-wire (with the cable length compensation), diameter 5,7 mm. <table border="0" style="margin-left: 20px;"> <tr> <td>20 °C (± 3 °C)</td> <td>(-25÷70) °C</td> </tr> <tr> <td>± 0,08 %</td> <td>± 0,13 %</td> </tr> </table> Pressure sensor p2 (internal, optional) – absolute or gauge, ranges from 0÷100mbar g to 10÷100 bar abs 2 digital pressure or temperature transducers (external, working on battery mode) 4 Ex digital outputs (separated): <ul style="list-style-type: none"> 1x configurable - binary or frequency (0-5000Hz), Counters: V_b, V_m, E 3x configurable binary 	20 °C (± 3 °C)	(-25÷55) °C	± 0,2 % of measured value	± 0,35 % of measured value	20 °C (± 3 °C)	(-25÷70) °C	± 0,08 %	± 0,13 %
20 °C (± 3 °C)	(-25÷55) °C								
± 0,2 % of measured value	± 0,35 % of measured value								
20 °C (± 3 °C)	(-25÷70) °C								
± 0,08 %	± 0,13 %								
Control outputs									





Communication

1. Direct transfer of data to system – Data readout through internal GSM/GPRS modem with the use of internal batteries



2. Remote data readout – connection through communication interfaces INT-S3, RTU controller independently

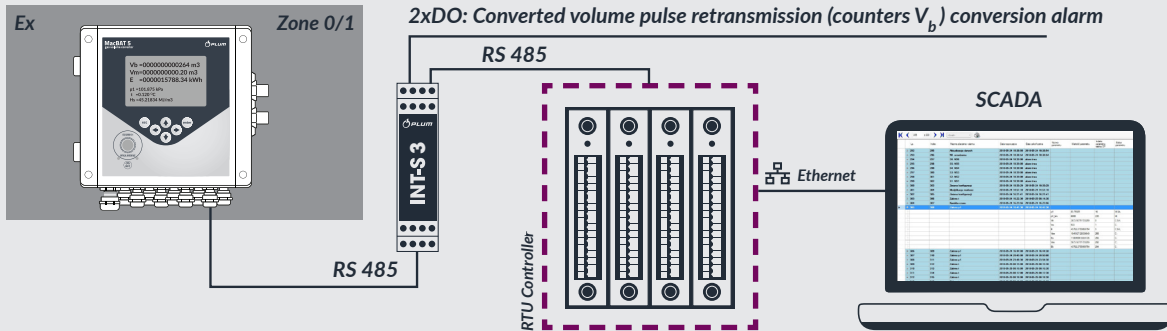

3. Process of measurement using MacBAT 5 and turbine gas meter

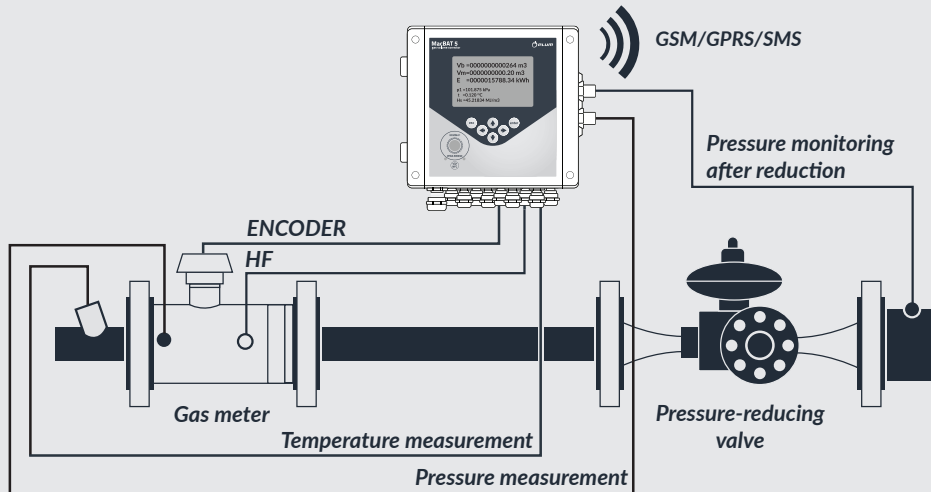

4. Process of measurement using MacBAT 5 (with external pressure sensor) and rotary gas meter

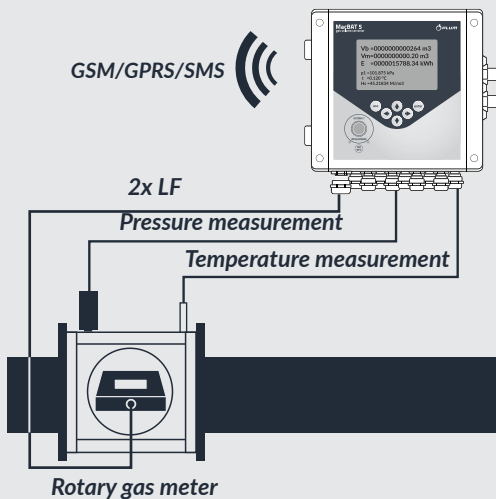

5. Local readout and configuration

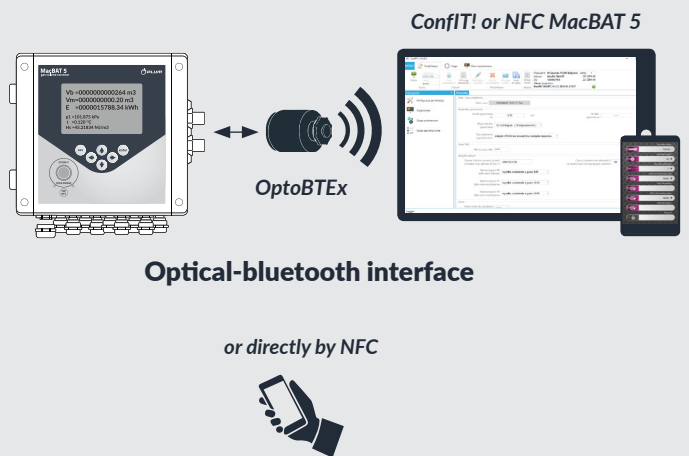

MacBAT 5 accessories



INT-S3 | Transmission interface

Performs as an external power supply to the intrinsically safe measurement device (located in stationary telemetric systems supplied from 11-30V DC or a battery that is located in explosive zone 0, 1, or 2). Additionally, data is transmittable to a readout device (i.e. computer) via RS485 port.

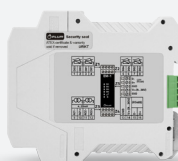

EM-1 | Extension module

Extends the functionality of MacBAT 5 by adding two additional current outputs operating in 4-20mA current loop and four binary relay type outputs. Can operate as a standalone device as it has its own parameters that can be modified remotely using MODBUS RTU transmission protocols. Data readout and modification can be performed with the use of SCADA system.

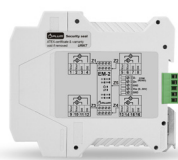

EM-2 | Extension module

Extends the functionality of the MacBAT 5 by adding eight additional digital inputs that operate as a NAMUR type or cooperate with Potential-free connector. Can also operate as a standalone device as it has its own table of parameters for remote modification using MODBUS RTU transmission protocols. Data readout and modification can be performed with the use of SCADA system.



OptoBTEX | Optical-Bluetooth Interface

A wireless transmitter of data from compatible devices. OptoBTEX is a wireless transmitter of data from compatible devices. The transmission is performed in Bluetooth 2.1+EDR Class 2 standard. Data is transmitted to a compatible device, which has IEC 62056-21 standard and the readout software installed (usually a mobile device running MS Windows or Android operating system). OptoBTEX does not modify data and wireless communication is performed in Bluetooth 2.1+EDR Class 2 standard.



NFC MacBAT 5 | Mobile application

MacBAT 5 EVC Android configuration application. Configuration available using OptoBTEX optical head or NFC interface. It is available for free download from the Google play service.



eWebTEL | Software

An online platform for Graphical visualization of aggregated data collected from monitored gas network (i.e. resolvers, manometers and recorders, geo-location of devices). Provides breakdown of recorded: history of consumption by each consumer, hourly peaks, time and quantity of failure occurrences, history of parameter values that define the condition of gas network.